

© COPYRIGHT 19 78 BY AMP INCORPORATED, HARRISBURG, PA. ALL INTERNATIONAL RIGHTS RESERVED. AMP INCORPORATED PRODUCTS COVERED BY U. S. AND FOREIGN PATENTS AND/OR PATENTS PENDING.

REVISIONS						
P	F	ZONE	LTR	DESCRIPTION	DATE	APPROVED
✓			C	REV PER EC 0730-0201-94	4-26-95	JH RS
✓						
✓						

- ⚠ SHEET METAL SCREWS NOT SUPPLIED.
- ⚠ INSERT IS ATTACHED TO STRAIN RELIEF. AS AN ADDITIONAL ADJUSTMENT FOR SMALL WIRE BUNDLES, IT SHOULD BE CUT OFF AND POSITIONED AS SHOWN BY DOTTED LINES.
- ⚠ TWO REQUIRED PER CONNECTOR.
- 4. DETACHABLE INSERT MAY SEPARATE FROM STRAIN RELIEF BODY DURING SHIPPING.

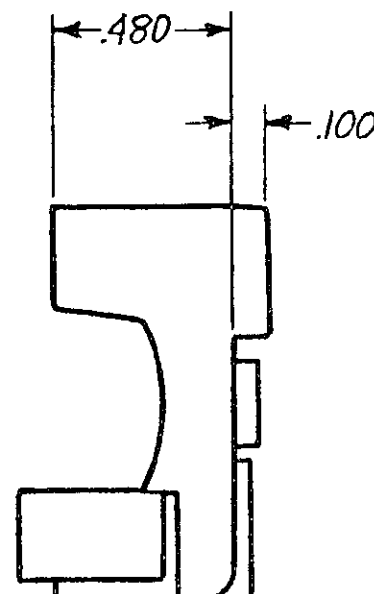
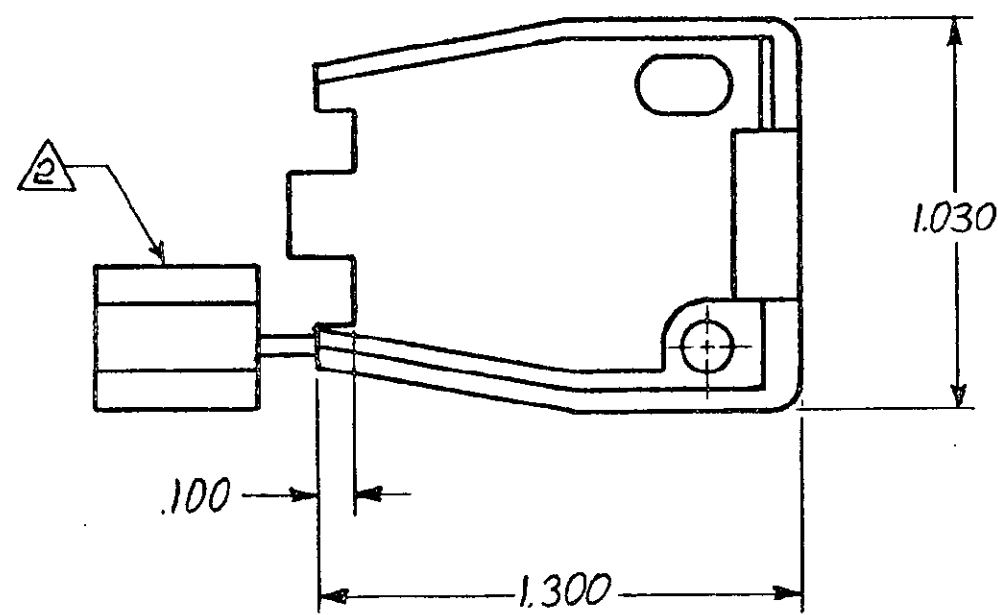

(2 REQ'D) #6 x .625 LG. TYPE "B" PAN HEAD SHEET METAL SCREW ⚠

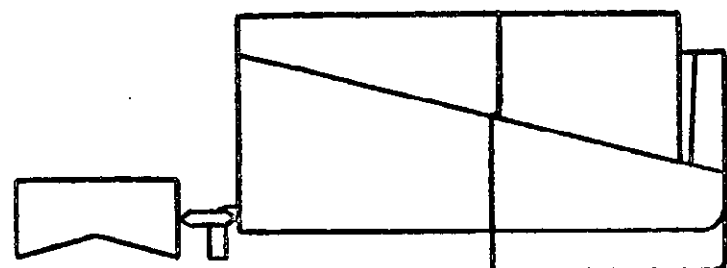
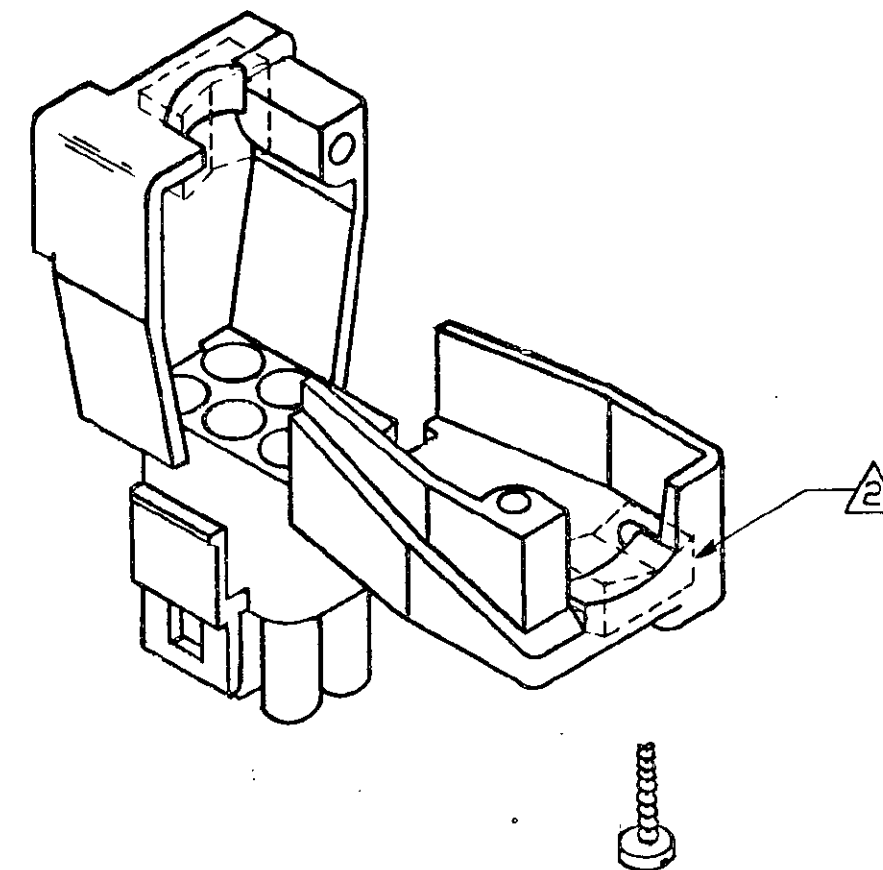

WIRE BUNDLE DIA		UNLESS OTHERWISE SPECIFIED DIMENSIONS ARE IN INCHES. TOLERANCES ON: DECIMALS ± .015 ANGLES ±	CONTRACT NO		NYLON 94V-0 640715-1	
WITHOUT INSERT	.650 MAX		DR	C. ERISMAN 10-2678	MATERIAL	PART NO
WITH INSERT	.120 MIN		CHK	D.S. Heide 11/1/78	AMP INCORPORATED Harrisburg, Pa.	
MATERIAL		SEE TABLE	APPD	NAME STRAIN RELIEF AND INSERT, 6 CIRCUIT, UNIVERSAL MATE-N-LOK™		
FINISH		SEE TABLE	APPD	DSGN APPD	SIZE	CODE IDENT NO DRAWING NO
			OTHER APPD		C	00779 640715
				SCALE	NTS	SHEET 1 OF 1

640715

640715